

Breadboard Power Supply Module 3.3V or 5V output
PART NO. 2217238

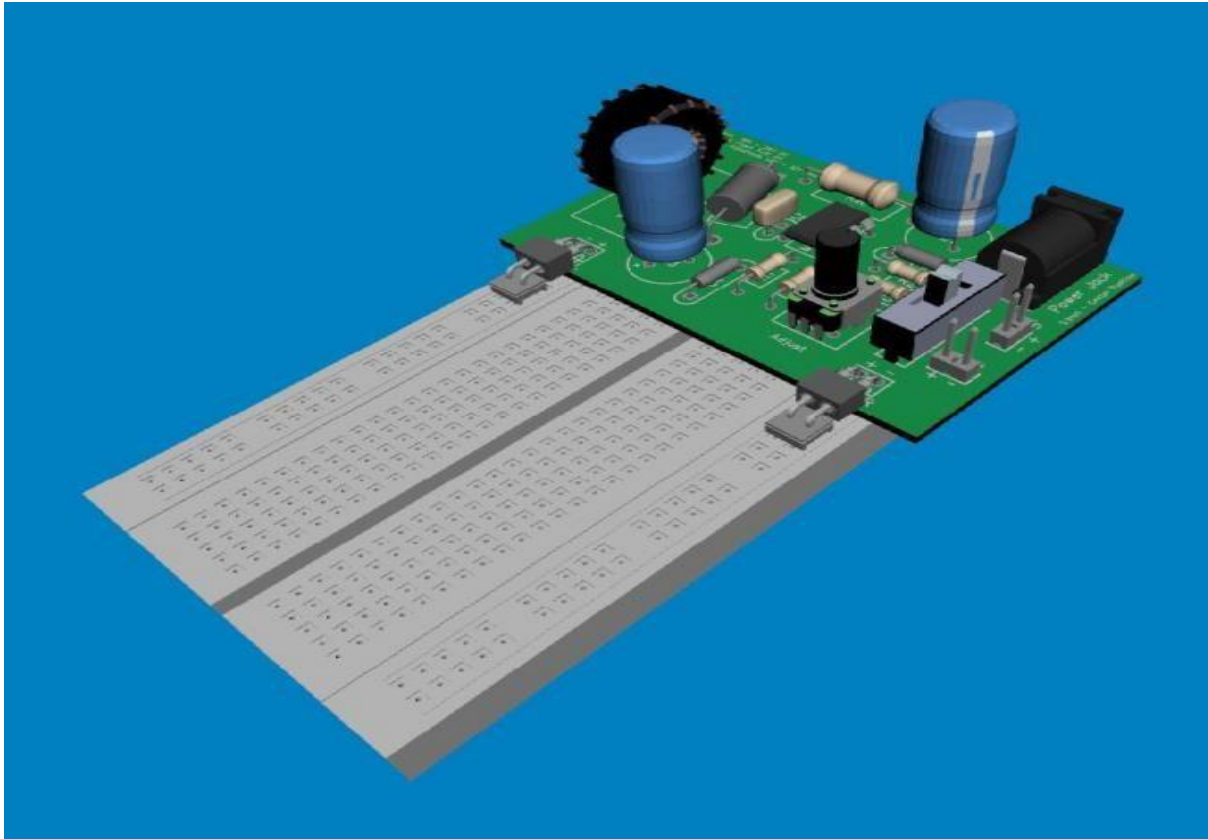

Specifications:

Input voltage: 10-24VDC, recommended 18V wall power supply (Power Jack)

Output voltage: 3.3V/5V/Adjustable 1.8-12V

Output current: 650mA

Pin Headers for input and output

Central positive DC 2.1 power jack for input

Size: 2.64" x 1.69"

By completing this kit user will get useful Breadboard power supply with 3.3V 5V or adjustable output modes which are selected by sliding switch. Also user will learn how switching mode power supply Buck converter works.

Switching mode power supply is much more efficient and have wider range of input voltages than linear regulator. Input voltage of this module is 10-24V DC (Recommended 18V wall power supply) (Power Jack with positive center pin) Maximum current at output of this power supply is 650mA and no heat sinks are needed.

Module also have adjustable voltage output in ranges between 1.8-12 Volts but in that case input voltage should be in range from 18 to 24 Volts, maximum output current in adjustable mode is 500mA.

If 10 Volts are applied on input - output voltage can be adjusted in range from 1.8V to 6V, maximum upper voltage level in adjustable mode is increased as input voltage increases.

3.3V 5V and adjustable modes are selected with three position slide switch, in adjustable mode voltage is adjusted with potentiometer.

Distance between closer pins on headers on opposite sides used for Breadboard inserting is 1.7 Inches (43.18 mm) and they fit on breadboard: Jameco Part no. 2212218 and any other breadboard which is built on that standard.

Module can't be inserted on some Breadboards so header on one side (Vout R or Vout L) should not be soldered if this module is used on that Breadboard with different dimensions between power rails.

PCB dimensions are 67 x 43mm (2.64 x 1.69 Inches)

This module will ideally work with 18V DC power supply adapter.

Possible adapter solution is Jameco Part no. 2102060 with Interchangeable AC plugs (plug kits sold separately)

AC-Plug-US, USA AC plug, Jameco P/N: 2082353

AC-Plug-EU, European AC plug, Jameco P/N: 2082361
 AC-Plug-UK, United Kingdom AC plug, Jameco P/N: 2082370
 AC-Plug-AU, Australian AC plug, Jameco P/N: 2082388
 AC-Plug-MIX, Kit includes US, EU, UK, & AU plug, Jameco P/N: 2082396

Time Required: 1 - 2 Hours depending on experience

Experience Level: Intermediate

Required tools and parts:

Soldering iron and solder
 Wire strippers and cutter
 Needle nose pliers
 DC power supply 10-24V

Bill of Materials:

Qty	Jameco SKU	Component Name
1	316945	MC34063 - DC Controller Single Output
1	371979	Inductor, toroid 1000.0 uH 1.3A
1	16088	Ct - 330pF 500 VOLT Mica Capacitor
1	606740	C3 - Capacitor 470 uF 25 Volt 20%
1	606820	C1 - Capacitor 220 uF 50 Volt 20%
1	690881	R1 - Resistor Carbon Film 1.2k Ohm 1/4 Watt 5%
1	690937	R2 - Resistor Carbon Film 2k Ohm 1/4 Watt 5%
1	690996	R3 - Resistor Carbon Film 3.6k Ohm 1/4 Watt 5%
1	690793	R4 - Resistor Carbon Film 510 Ohm 1/4 Watt 5%
1	2118791	Pot - 10k Potentiometer Single Turn
1	1383998	Rsc - 2 Watt 0.39 Ohm Metal Film Resistor
1	103393	Vin Vout - Header straight male,1 row, 10PIN
1	101179	2.1mm Male DC Power Jack
1	177990	1N5822 - Diode Schottky 40 Volt 3A
1	2181061	S - Single Pole 3 Throw Top Slide Switch
2	536542	C2 C4 - Capacitor 0.1 uF 50 Volt, Axial
1	2076851	Right Angle Male Header
1	2100321	Vout R Vout L - Right Angle Female Header
1	112206	Socket IC 08 Pin
1	---	PCB

Step 1 - MC34063AP1

The use of switching regulators is becoming more pronounced over that of linear regulators because the size reductions with new equipment and designs require greater conversion efficiency. Another major advantage of the switching regulator is that it has increased application flexibility of output voltage.

The MC34063A Series is a monolithic control circuit containing the primary functions required for DC to DC converters. These devices consist of an internal temperature compensated reference, comparator, controlled duty cycle oscillator with an active current limit circuit, driver and high current output switch. This series was specifically designed to be incorporated in Step Down and Step Up and Voltage Inverting applications with a minimum number of external components.

Features:

Operation from 3.0 V to 40 V Input
 Low Standby Current
 Current Limiting
 Output Switch Current to 1.5 A
 Output Voltage Adjustable
 Frequency Operation to 100 kHz
 Precision 2% Reference

Current limiting is one nice feature which makes sure that device don't burn down if we connect load which will pull big current from power module. 100 kHz is maximum frequency for turning on and off power switch.

The switching regulator consists of a stable reference and a high gain error amplifier identical to that of the linear regulator. This system differs in that a free running oscillator and a gated latch have been added. The error amplifier again monitors the output voltage, compares it to the reference level and generates a control signal. If the output voltage is below nominal, the control signal will go to a high state and turn on the gate, thus allowing the oscillator clock pulses to drive the series "â" pass element alternately from cutoff to saturation. This will continue until the output voltage is pumped up slightly above its nominal value.

The increase in conversion efficiency is primarily due to the operation of the series \hat{a} pass element only in the saturated or cutoff state. The voltage drop across the element, when saturated, is small as is the dissipation.

More information about working of this chip can be found on this source:

http://www.onsemi.com/pub_link/Collateral/AN920-D.PDF

This kit includes 8 pin socket and that socket is first soldered to the PCB board, align little notch on front of socket with notch on the silkscreen image. Tape can be used to secure socket in position while soldering.

MC34063 have eight pins and there should be no problems placing them in the socket.

Little notch on chip front should be lined up with notch mark on silk screen image and socket.

If needed chip legs can be bent little inside, do that by placing chip on side and then push little towards table to bend all legs at the same time.

Socket is used to prevent possible damage to MC34063 due to heating from soldering.

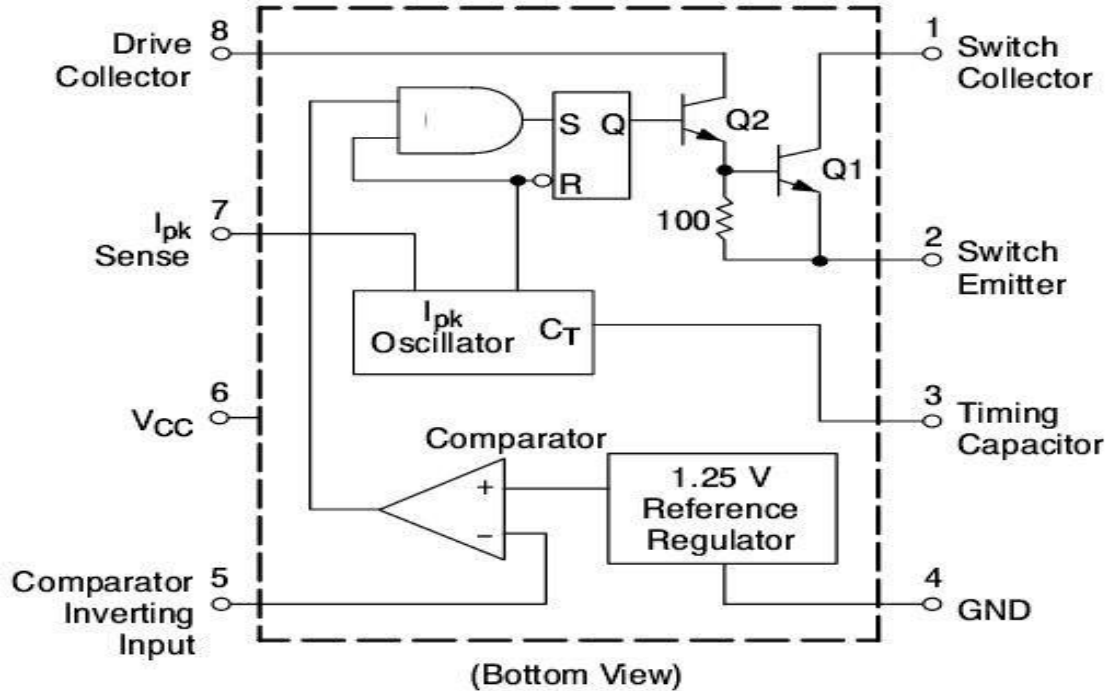

Step 2 - Timing capacitor

Timing capacitor in circuit is used to determine frequency on which circuit will work. During charging period of the capacitor switch could be turned on if comparator output which is fed to NAND gate gives logic 1, switch can be only turned off if capacitor is in discharging mode because he is only one able to break latch circuit which keeps switch turned on. So if feedback tells to turn off switch by giving 0 logic state on the comparator output, switch will not turn off until capacitor starts to discharge and break latch by giving 0 logic state both to latch and NAND gate input.

Capacitor used in this design is 330 pF Mica capacitor which is not polarized so component can be placed on board in both directions, capacitor is designated with number 331. Capacitor designation on silk screen and schematic is Ct.

Place the tip of your soldering iron at the joint where the capacitor leg and the edge of the hole meet. Press the solder into this junction so it melts and flows freely. Once the junction is covered, remove the iron and solder.

Repeat for the other leg. Once both legs are soldered, take your small snips and snip the capacitor legs just above the solder.

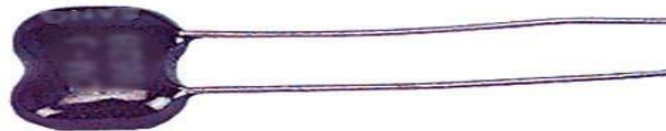

Step 3 - Resistors

Resistors in this circuit are used for creating voltage divider for negative return connection. That voltage between two resistors in voltage divider is supplied to comparator which compares that value with reference value of 1.25 Volts. When voltage value at voltage divider is less than 1.25V comparator outputs high digital state and turns on switch when timing capacitor starts to charge.

There are few resistor values: 1.2k Ohms designated with Brown Red Red Gold

2k Ohms - Red Black Red Gold

3.6k Ohms - Orange Blue Red Gold

510 Ohms - Green Brown Brown Gold

Combination of 1.2k resistor and 2k resistor is used for keeping output voltage on 3.3V, 1.2k and 3.6K resistor gives voltage reference for 5V and combination of 510 ohms resistor 10k potentiometer and 1.2k resistor gives possibility of adjusting output voltage in range between 1.8V and 12V.

Slide resistor legs through the holes. Once the resistor is in place, you can bend the legs out slightly to hold it in place when board is turned upside down.

Place the tip of your soldering iron at the joint where the resistor leg and the edge of the hole meet. Press the solder into this junction so it melts and flows freely. Once the junction is covered, remove the iron and solder.

Repeat for the other leg. Once both legs are soldered, take your small snips and snip the resistor legs just above the solder.



Step 4 - Short circuit resistor

Short circuit resistor is used for sensing current value and its limiting if necessary.

Current limiting is accomplished by monitoring the voltage drop across an external sense resistor placed in series with VCC and the output switch. The voltage drop developed across this resistor is monitored by the Ipk sense pin. When this voltage becomes greater than 330 mV, the current limit circuit provides an additional current path to charge the timing capacitor Ct. This causes it to rapidly reach the upper oscillator threshold, thereby shortening the time of output switch conduction and thus reducing the amount of energy stored in the inductor.

This resistor is designated as Rsc in schematic and silkscreen image. This is not polarized element (like every resistor) so it can be placed in both directions.

Place component on its place by bending its legs for 90 degrees so that distance between leads is 17.78mm and then put it through holes. To secure it in position you can bend the legs out slightly to hold it in place when you turn the board upside down. Solder it and snip excess leads.



Step 5 - Axial ceramic capacitors

Electrolytic capacitors used in this circuit are aluminum ones with bigger ESR (Equivalent series resistance) in order to lower that ESR and losses generated because of it those ceramic capacitors with small ESR are connected in parallel with input and output electrolytic capacitors.

When we connect two resistances in parallel total resistance is smaller than the smallest resistance connected in parallel. $1/R_t = 1/R_1 + 1/R_2$

Capacitance of those ceramic capacitors is 0.1 uF and they are designated with number 104. They are not polarized so they can be soldered in both directions on their place.

To place capacitors in their place designated with C4 and C2 bend their legs for 90 degrees since they are axial ones, and distance between leads should be 8.89mm.

Place them through holes bend legs so that they are kept in position and solder them. After soldering snip excess leads.



Step 6 - High speed switching diode

Purpose of this diode is simple to conduct when necessary. Diode conducts when switch inside MC34063 turns off and only source of power in circuit for load is inductor, but now inductor's magnetic field creates current of opposite direction so anode will be on positive and cathode on negative voltage and diode will start to conduct.

Diode will stop conducting when switch turns off and connects toroid inductor with positive input voltage so diode's cathode will also be on positive voltage and thus will not conduct.

1N5822 high speed switching diode have 3A peak forward current but peak current in this circuit will be 900mA maximum so why is it using 3A 1N5822 diode instead of 1A 1N5819? Well it is simple because 1N5822 diode have smaller voltage drop when conducting so efficiency will be slightly improved, it will be more resistant to short circuit and will last much longer.

Diode must be high speed switching schottky diode because of the high frequency switching in circuit - the diode will conduct and be turned off for short period of time.

To place diode on the board refer to the silk screen image - diode is designated with 1N5822, cathode is designated with the different color band which is aligned with the line on the one side of silkscreen diode image.

Firstly bend legs for 90 degrees so that distance between them is 18.84mm then place diode through holes solder it and snip excess leads.

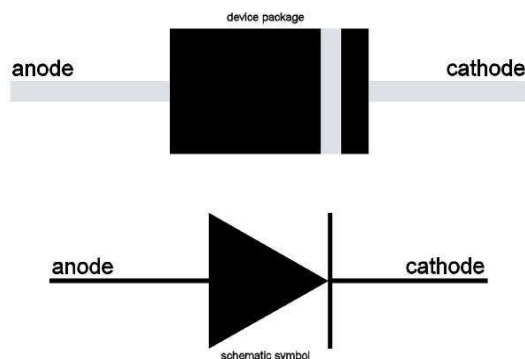

Step 7 - Slide switch

Slide switch have three positions ON-ON-ON (3.3V - 5V - Adjustable). Common pin is connected with 1.2k resistor and depending in which position is switch that com pin is connected to 2k, 3.6k resistors or 510 ohm resistor and 10k ohm potentiometer. Slide switch is used to choose mode in which will power module work. Switch can be soldered only in one way to the PCB.

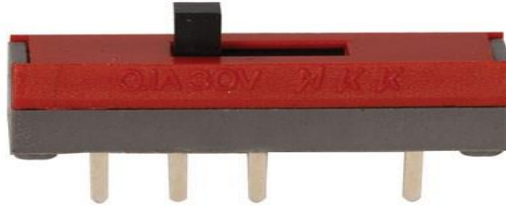

Step 8 - Pin headers

This kit includes one 10 pin straight male breakable header. For this power module we need to break this 10 pin header in way that we get two headers with two pins, one two pin header for input voltage (V_{in}) and other for output voltage (V_{out}). Take two pin headers and Insert their shorter ends into the board on their place, use tape to hold them in position, turn board and solder them.



Step 9 - Potentiometer

Potentiometer is used in combination with 510 ohms resistor and 1.2k ohms resistor to create voltage divider. When user increases resistance with potentiometer output voltage rises. When potentiometer value is at 0 than there is combination of 1.2k ohm resistor and 510 ohms resistor which gives 1.8V on output. That voltage from voltage divider is fed into MC34063 comparator together with reference voltage of 1.25 volts. Potentiometer is placed on his place near slide switch it can be placed to fit in rectangle on silkscreen or in opposite way.



Step 10 - Electrolytic capacitors

A capacitor (originally known as a condenser) is a passive two-terminal electrical component used to store energy electrostatically in an electric field.

There are two electrolytic capacitors input 220 uF and output 470 uF capacitor. Input capacitor makes sure that input voltage is without big ripples so that clean DC voltage is supplied to MC34063 chip and other parts of circuit (when supply voltage drops for small period of time that lost power will be supplied to circuit from capacitor).

Turning on and off switch inside MC34063 creates voltage ripple and in order to make it small as possible larger capacitance capacitor is used.

Input capacitor is designated as C1 on silkscreen. His capacitance is written on its body and longer lead is positive one (+). Output capacitor have bigger dimensions, his capacitance is also written on its body and longer lead is also positive one.

Place them in their positions through holes and make sure to place positive lead through hole which have + near it, to keep them in position bend leads a bit and solder them. After soldering snip excess leads and that is it.

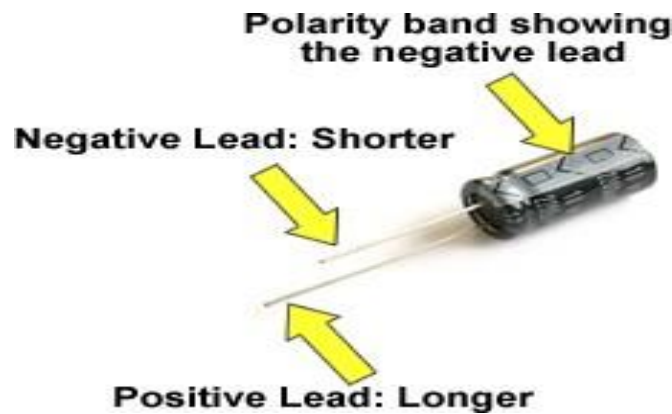

Step 11 - 2.1 mm power jack

This power supply module have option to be supplied by 2.1mm dc power jack with positive center pin. This connectors which fit in 2.1mm power jack are often found on power supply wall adapters (Jameco Part no. 2102060). Those power adapters with positive center pin have designation like on picture above.

This module will ideally work with 18V input power supply adapter.

One of this adapters with positive center pin is Jameco Part no. 2102060 with Interchangeable AC plugs (plug kits sold separately)

AC-Plug-US, USA AC plug, Jameco P/N: 2082353

AC-Plug-EU, European AC plug, Jameco P/N: 2082361

AC-Plug-UK, United Kingdom AC plug, Jameco P/N: 2082370

AC-Plug-AU, Australian AC plug, Jameco P/N: 2082388

AC-Plug-MIX, Kit includes US, EU, UK, & AU plug, Jameco P/N: 2082396

To install this power jack use enough amount of tin to achieve greater mechanical resistance due pulling out and putting in power adaptor connector inside 2.1mm power jack.

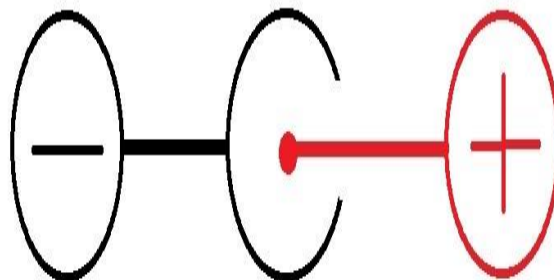

Step 12 - Inductor

Inductor is just simple wire wound around ferrite core. Ferrite core is used to reduce losses and heating inside it during work with high frequencies.

Inductor function in this circuit is to store energy in the form of the magnetic field, when the switch inside MC34063 is turned on current is flowing through inductor and creates magnetic field, when chip turns off switch that stored energy is starting to flow in to the output capacitor and load. As the magnetic field in the inductor starts to collapse, it generates a reverse voltage that forward biases diode 1N5822, and the peak current will decay.

DC output voltage can be set to any level less than the input by controlling the percent conduction time of switch to that of the total switching cycle time.

Capacitor is taking care that voltage supplied to load is constant as much as possible.

Inductance of this inductor is large because larger inductance is needed with small currents on the output to prevent current dropping to 0.

Most of the designs only assumes that device will give maximum current all the time, and when load gets lower converter starts to work in discontinuous mode and that means that magnetic field in inductor collapses to 0 due to small inductance and only energy available for load is from capacitor and in that time larger voltage ripple than nominal occurs.

To place this inductor on board simple place it on its place referring to silkscreen image (Marked with "Toroid inductor"), after soldering it on board snip the excess leads.



Step 13 - Headers for connecting to breadboard

Firstly female connector should be broken in order to get two headers each with two pins. Then they should be soldered on their place on PCB designated with Vout L and Vout R.

Now in same way male header should be broken, but those male headers will not be soldered to PCB, instead they will be simply inserted in female header with longer part. Shorter part then can be inserted in Breadboard.

Male pin header pins should be 5 -7mm below PCB level and then those headers can be inserted in Breadboard.

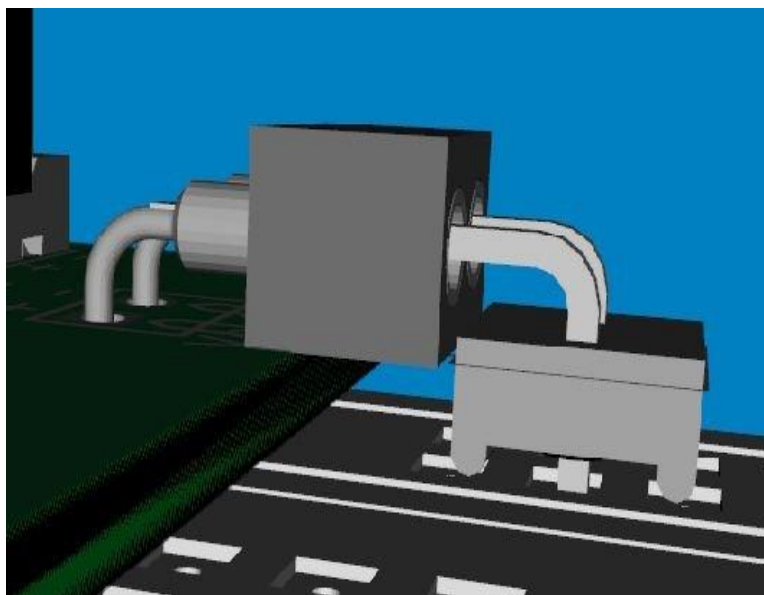

Step 14 - Breadboard standard dimensions

Distance between closer pins on headers on opposite sides for Breadboard inserting is 1.7 inches (43.18 mm) and they fit on Breadboard: Jameco Part no. 2212218 and any other Breadboard which is built on that standard.

If module can't be inserted on some Breadboards then header on one side (Vout R or Vout L) should not be soldered.

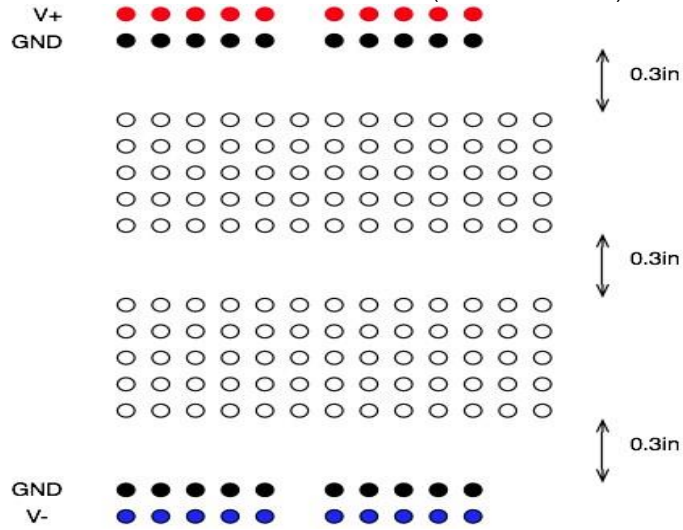

Step 15 - Schematic

Schematic shows exact and clearer component connections than PCB board, and also there could be seen component designations.

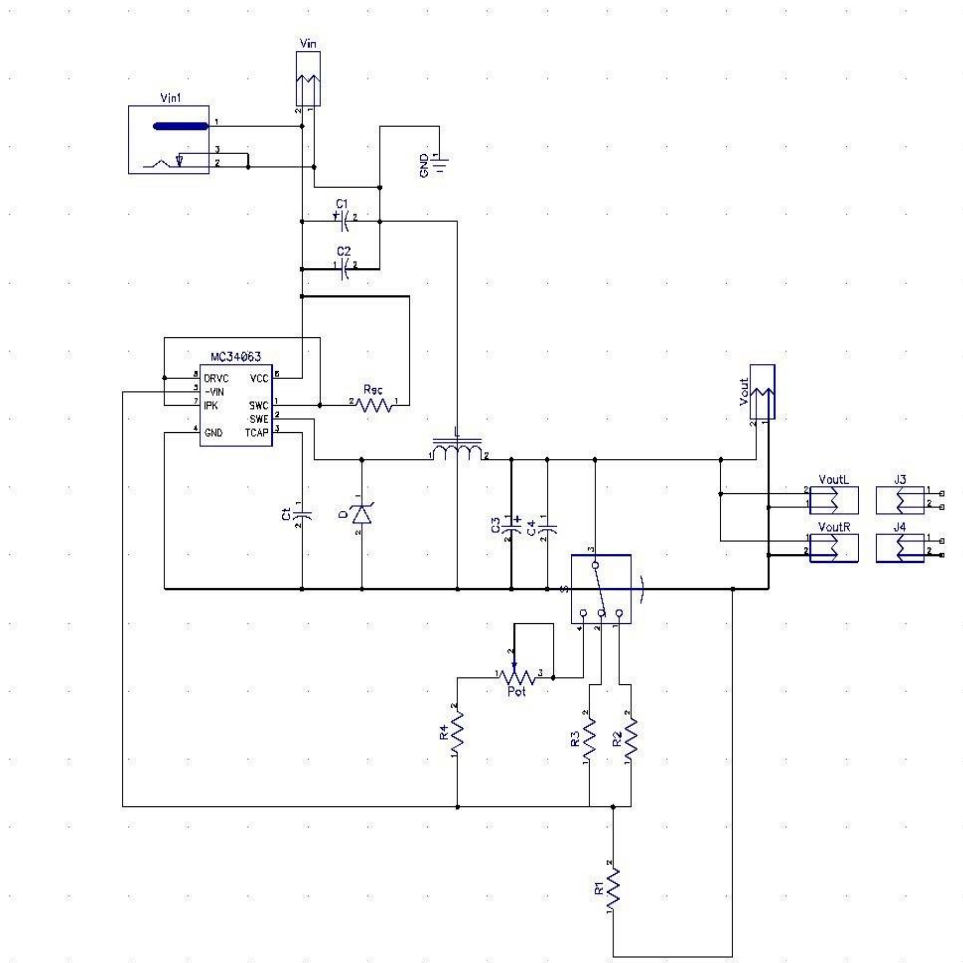

Step 16 - Power supply seen from above and its dimensions

Image can help with assembling of the module and also shows dimensions.

Some 3D models are not 100% exact.

